

Installation Guide

Part No: CTSMZ012.2 Mazda Can-Bus Steering Wheel Control Interface

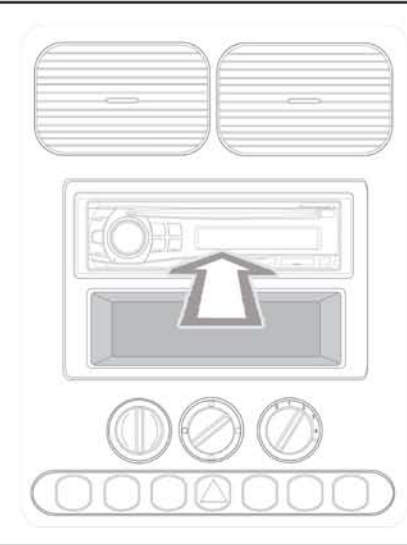
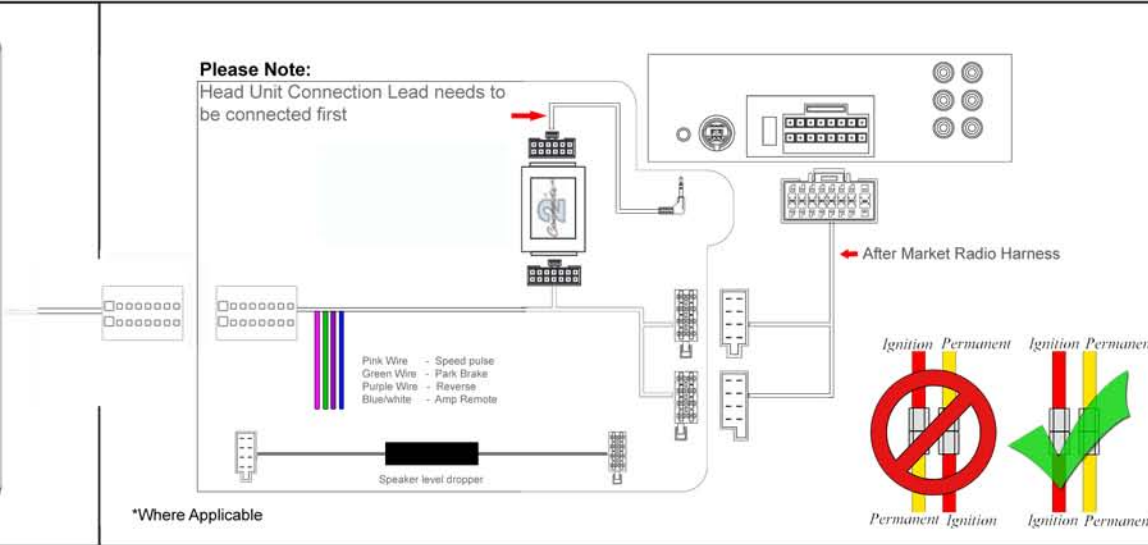
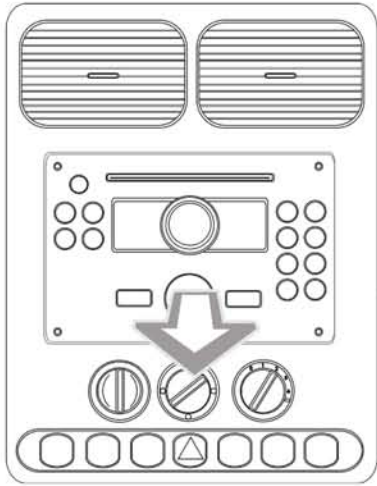

Vehicle Compatibility:

Mazda MX-5 2005 >
Mazda RX-8 2003 >

with Amplified Bose System

Steering Wheel Control Functions



* Note All Dates are guide lines only as specifications of vehicles change

User Guide

Steering wheel control Interface



To adjust Clock:

1. Press and hold MODE button for 2 seconds.
2. The vehicle screen will now display "SETTINGS"
3. Press MODE button to select this option.
4. The screen will now display "INFO/CLOCK"
5. Press and hold track down to enter time adjust mode
6. Press track up to increment the time digit
7. Press track down to move onto next time digit.
8. Press MODE button to exit or wait for 10 seconds

To adjust Fader:

1. Press and hold MODE button for 2 seconds.
2. The vehicle screen will now display "SETTINGS"
3. Press the track down button until the vehicle display shows "FADER ADJUST"
4. Press the MODE button to select this option.
5. Using the track up and down button will now adjust the vehicles fader.
6. Press MODE button to exit or wait for 10 seconds

To access Trip information:

1. Press and hold MODE button for 2 seconds.
2. The vehicle screen will now display "SETTINGS"
3. Press MODE button to select this option
4. The screen will now display "INFO/CLOCK"
5. Press track up (do not hold) to access Trip information
6. Keep pressing track up to scroll through different trip information.
7. Press track down to return to clock display
8. Press MODE button to exit or wait for 10 seconds