

Gateway 500s

iPod, USB, Bluetooth (HFP, A2DP)

G52-9202-1



Installation Guide

DENSION

1. Introduction

The Dension Gateway 500s lets you connect your iPod or USB storage (stick, hard drive or mass storage capable mp3 player) to your original car radio, providing music playback, menu based control and charging.

The Gateway 500s also offers Bluetooth connectivity for handsfree mobile call and music streaming (via A2DP) using the original buttons and screens of your vehicle.

Package content

- Gateway interface
- Fibre optic cable kit
- Connector Port
- iPod / iPhone dock cable
- Power harness
- Instruction manuals (install/user)
- Microphone

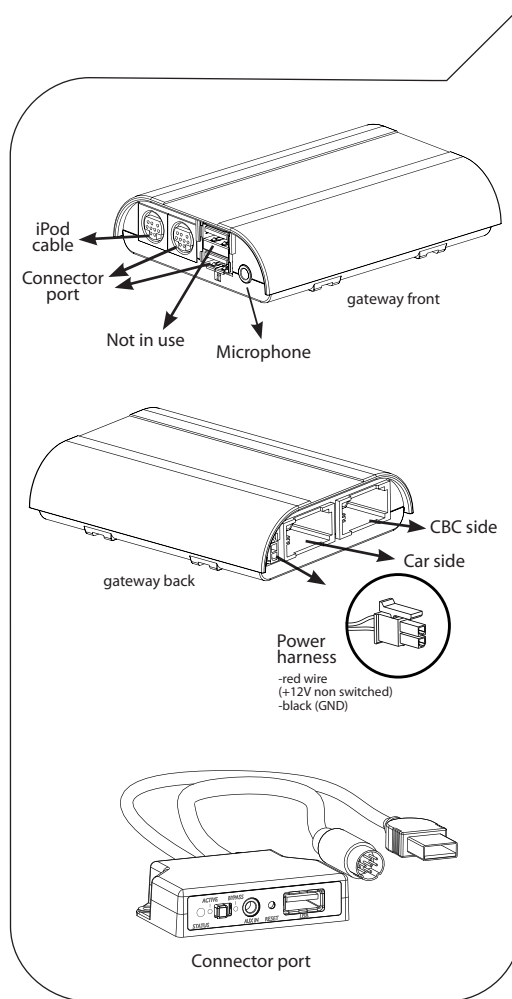

2. Programming

The Gateway 500s emulates a CD changer and uses CD changer controls to access offboard audio sources therefore it may be necessary to have the car programmed by your dealer in order to use the GW500s with it.

Programming the car for GW500s

Audi

No programming required

BMW non CIC (non iDrive Professional, M-ASK & CCC Prof.)

Installation in BMW models:

Factory phone modul is available or coded

Options	E60* M-ASK	All other models (except E65*)
original CD changer fitted and MP3 capability is already available	convert CD Changer option to „IPOD“ retrofit	no programming required
original CD changer fitted and no MP3 capability is available.		retrofit “KMP3” option with service computer
original CD changer not fitted	retrofit “IPOD” option with service computer	

Factory phone modul is not available or coded

Options	E60* M-ASK	All other models (except E65*)
original CD changer fitted and MP3 capability is already available	convert CD Changer option to „IPOD“ retrofit & program the phone option	program the phone option
original CD changer fitted and no MP3 capability is available.		retrofit “KMP3” option and program the phone option with service computer
original CD changer not fitted	retrofit “IPOD” option and program the phone option with service computer	

Important note:

- If the SW of the car requires an update or a KMP3 activation, **switch the Gateway to bypass/service mode before you start the procedure.** Before converting or retrofitting IPOD option, switch back to GW mode.

- 1 - E65 means all 7 series model variations (E65/E66)
- 2 - E60 means all 5 and 6 series model variations (E60/E61/E63/E64)
- 3 - the car is MP3 capable if the front CD-Slot reads MP3 audio discs and the ID3 tags are visible on the display

Mercedes

Generally no programming is required but in some cases (e.g. no device was connected onto the optical ring) a CD changer will have to be enabled with the service computer.

Porsche

Generally a CD changer and phone option will have to be enabled with the service computer.

3. Device Installation

The 500s can be installed anywhere on the MOST ring, however in order to **avoid any compatibility or functional issues**, please make sure that the Gateway 500s is the **last connected device** on the MOST ring or it is **connected to beside** the factory CD-Changer (if available). **Please note:** Installation of the Gateway 500s is very complex, therefore please have it installed by Professional Installer.

MOST ring installation

Disconnect the fiber optic Male connector from the original interface (e.g. Head Unit) then remove the fiber optic housing from the Male connector and finally disconnect (Fig. 1.) the fiber optic fibre (the one which is marked to be the **‘signal in’** cable – with an arrow) as it is shown below

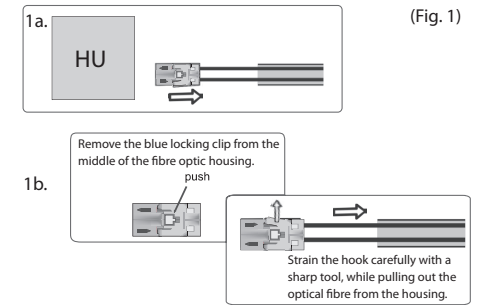

Connect that optical wire (use the optical male /male inline connector) with the **‘signal in’** cable of the Dension device. The optical fiber **‘signal out’** fibre of the Dension device must be connected to the original optic housing. Finally, take the Male connector and connect it to the original interface. At the end of the installation **please make sure that the light directions of the MOST optical ring are correct.**

Installation Type 1 (Fig. 2) :

Vehicles supporting multiple CD changers and equipped with a CD changer

- Audi A4/S4/RS4/A5/A6/S6/RS6/A8/Q7 with MMI-2 High (colour)

These vehicles allow you to select between Gateway audio sources and the original CD changer through the existing car audio controls.

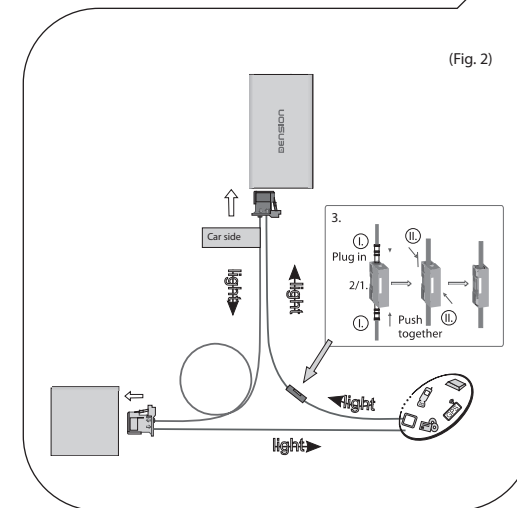

Installation Type 2a (Fig. 3):

This installation type is possible with the dual FOT GW 500s only.

Vehicles with an existing CD changer

These vehicles allow you to select between Gateway audio sources and the original CD changer by switching the modes between Gateway (active) and Bypass mode.

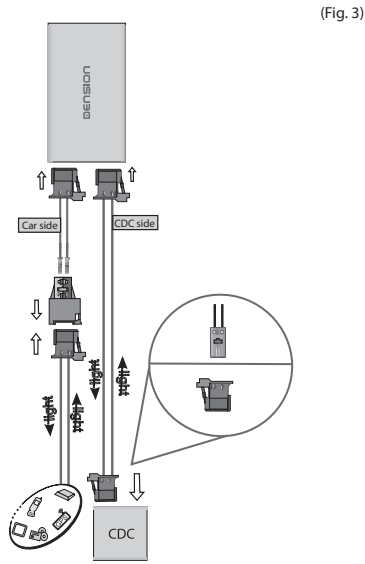

(Fig. 3)

Please note: Optical extension cable (FOA1PO1) is recommended on Porsche Cayenne due to the location of the factory CD-Changer (trunk).

Installation Type 3a (Fig. 4):

Vehicles with no existing CD changer Set the DIP switches as shown accordingly.

If you are connecting Gateway 500s to the back of the head unit, use this diagram:

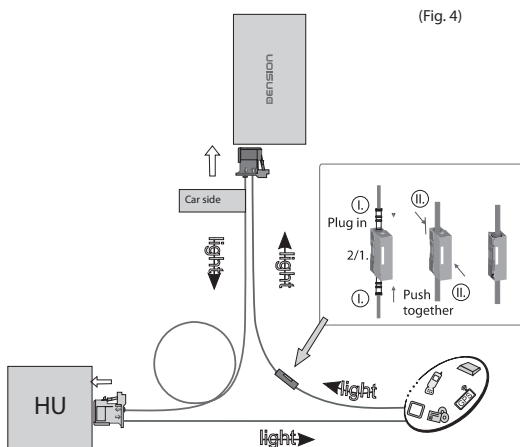

(Fig. 4)

Installation Type 3b (Fig. 5):

If you are installing to a free fibre optic connector in the car (CD Changer preparation):

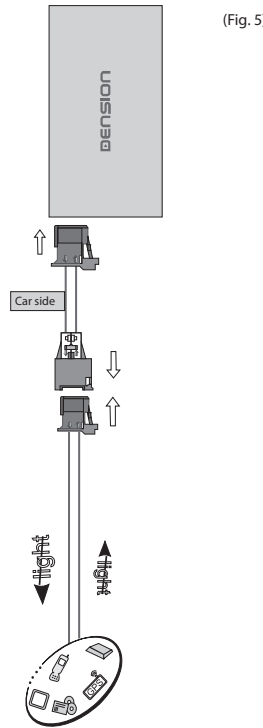

(Fig. 5)

4. DIP SWITCH SETTINGS

Set the DIP switches according to your car type:

Audi (MMI-2 High colour & Basic monochrome)

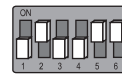

Text capable BMW E87, E90, E91, E92, E93, E60/61, E63/E64, E65/E66 (03/2005-) & E70 (non CIC)

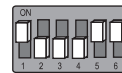

Mercedes (NTG1-, NTG2- Comand)

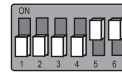

Porsche (PCM I/II/2.1)

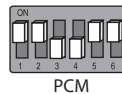

Please note: Disconnect the power cable from the GW 500s when changing the DIP settings.

5. CONNECTOR PORT

On the connector port there is a mode selector switch to toggle between Active / Bypass mode. In Bypass mode (LED flashes), the Gateway 500s will be fully 'invisible', so no functions - as media playback from iPod or the phone - will be accessible.

Use this mode if:

- 1, You want to use the original CD Changer (if available)
- 2, If the car is taken to service

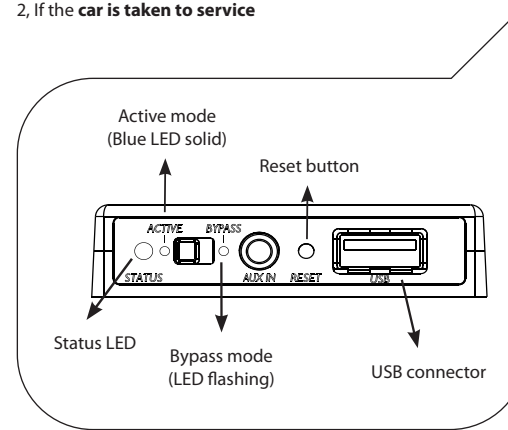

6. PHONE:

Compatibility (minimum requirements):

- Porsche with PCM 2 / 2.1 Head Units, where 'Phone' button exists
- Audi with MMI High and Basic Head Unit with SWC buttons
- BMW 1/3/5/6/X5
- Mercedes (NTG 1 & NTG 2) Comand Head Units

Please note: If it is needed, enable the factory Bluetooth module with a diagnostic computer (Typically on BMW and Porsche).

DIP switch #6 is designed and used for phone function. If you want to **use the factory phone** instead of the Gateway 500s phone option, please leave that **DIP switch (#6) OFF**.

Remove (loop) the factory phone from the MOST ring (if available) **if the Gateway 500s will be used** for phone functions as well.

7. POSITIONING THE MICROPHONE

For optimum handsfree performance, position the microphone as close to the driver's mouth as possible, but at the same time in a central location, i.e. an equal distance from the left and right speakers. Ideally, clip the microphone to an overhead panel at the top of the windscreen, for example, near the interior light.



8. TROUBLESHOOTING

Symptom	Cause	Solution
Status LED is OFF constantly on the connector Port	There is a brake on the MOST ring or missing power	Check the installation, make sure that the light directions and the optical connections are fine
Gateway is not recognised	Wrong DIP switch settings or the CD-Changer function is not activated	Check the DIP switches, program the required function (check section #2)
Amplifier or other factory device is not available when Gateway is in active mode	Installation issue	Please check if the factory device works in Bypass mode. If yes: Please change the installation sequence of the GW500
CD source option or CD magazines are greyed out (on BMW)	Programming issue	The car needs to be programmed. For further details, please read the installation notes at section 2.
Always starts in AUX mode or the phone needs to be paired at startup or always the first track is being played at startup from USB	Wrong Power connection type	Make sure that the power is constant 12V
NO text display when iPod GW mode or USB source selected (on Audi)	Wrong MMI setting	Check the CD-Changer settings on your MMI Menu and enable CD Text option
NO text display when iPod is connected	iPod UI is selected	change the iPod mode to iPod Gateway mode

9. DISCLAIMER AND WARRANTY

Disclaimer

If your car's electrical system begins to behave erratically, please disconnect the Activator tool and the Gateway interface immediately and have it checked by your installer. Dension and its authorized distributors and retailers are not liable for any incidental consequential or indirect damages or loss and do not assume liability for any diagnostic fees.

Dension reserves the right to modify its products or specifications without prior notice.

Warranty

Dension devices carry a one-year limited warranty that protects you from defects in material and workmanship of products sold by Dension or its authorized distributors and retailers. Dension does not warrant any installation work or assume liability for any damage caused due to negligence, improper installation or operation. For warranty claims, proof of purchase is required.

Further assistance

If you need further assistance in using your Dension product, please contact your local supplier or visit www.dension.com and click on 'Support'.

If any problem arise during the activation procedure, please check the download section for the latest firmware version and product documentation, as these may provide additional features, compatibilities or descriptions.